



TX, TXD & TXSD Series

Sliding Vane Pumps

Reliability

Durable pumps for fast and quiet operation. Sliding vane design provides sustained performance and trouble free operation.

Unique Features

Adjustable relief valve protects pump from excessive pressure. Optional air operated relief valve offers easy hose and nozzle handling. T-type strainers are available to protect pumping systems from damage caused by welding slag and foreign matter in the piping and tanks.

Sizing Options

Available in 1.5, 2, 2.5, 3, and 4-inch port sizes with flow rates from 10 to 500 U.S. gallons (2 to 113 m³/H) and pressures up to 125 PSI (8.6 bar).

Applications

- Fuel oil delivery truck
- Fleet refueling
- Lube oil
- Aviation refuelers
- Transport of
 - petro chemicals
 - gasoline
 - biofuels
 - solvents
 - and many more

TXSD models are equipped with a nickel-plated relief valve ideal for handling solvents, and FKM elastomers that are compatible with all Biodiesel and Ethanol blends.

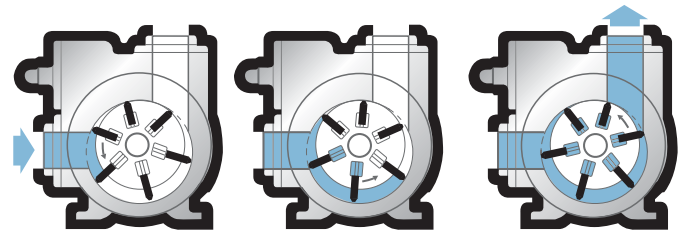
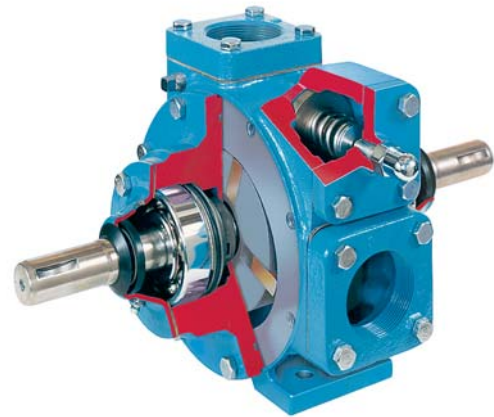

How Blackmer's sliding vane action works





TX, TXD & TXSD Series Sliding Vane Pumps

Performance Data

Pump Model	TX1.5			TX(S)D2		TX(S)D2.5		TX(S)D3		TX4	
Rated Pump Speed	780	600	400	640	520	640	520	640	520	500	400
GPM	52	40	25	72	58	120	98	263	211	505	405
LPM	197	151	95	273	220	454	371	995	799	1911	1533
M ³ /H	12	9	6	16	13	27	22	60	48	115	92
HP	5.9	4.5	3.2	3.0	2.5	5.0	3.8	9.5	7.8	17.5	15
KW	4.4	3.4	2.4	2.2	1.9	3.7	2.8	7.1	5.8	13.0	11.2

* Appropriate capacities and horsepower (HP) are based on a 100 SSU (22 Cps) fluid at a 50 PSI (3.4 bar) delivered pressure. Refer to Characteristic Curves for flow rates and torque requirements at other pressures and viscosities.

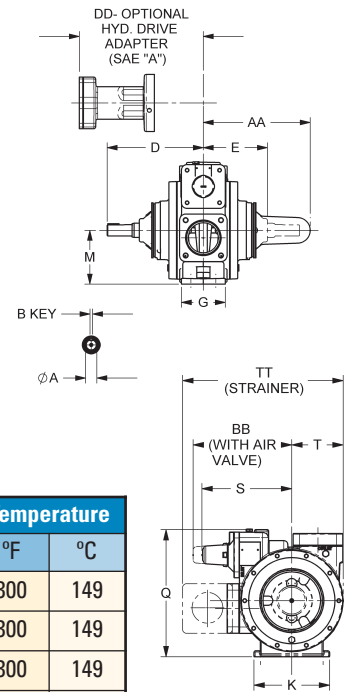

Maximum Operating Limits

Pump Model	Nominal Flowrate		Pump Speed	Viscosity		Differential Pressure		Working Pressure		Temperature	
	GPM	LPM	RPM	SSU	C _p	PSI	BAR	PSI	BAR	°F	°C
TX1.5	56	212	780	20,000	4,250	125	8.6	175	12.1	300	149
TX(S)D2	87	329	780	20,000	4,250	125	8.6	175	12.1	300	149
TX(S)D2.5	157	594	780	20,000	4,250	125	8.6	175	12.1	300	149
TX(S)D3	270	1,022	640	20,000	4,250	125	8.6	175	12.1	300	149
TX4	505	1,911	500	20,000	4,250	125	8.6	175	12.1	240	116

Dimensions

Model		A	B	D	E	G	K	M	Q	S	T	AA	BB	DD	TT	Approx. Wt.	
TX1.5	in.	1 ¹ / ₈	1 ¹ / ₄	7 ¹³ / ₁₆	5 ¹ / ₁₆	3 ¹ / ₈	6 ¹ / ₂	4	8 ¹ / ₂	7	3 ⁹ / ₁₆	—	—	10 ³ / ₈	—	61 lbs.	
	mm	—	—	198	129	79	165	102	216	178	90	—	—	264	—	28 kg	
TX(S)D2	in.	1 ¹ / ₈	1 ¹ / ₄	8	5 ¹ / ₄	3 ¹ / ₂	6 ¹ / ₂	4	8 ¹¹ / ₁₆	6 ¹ / ₈	3 ⁷ / ₈	8 ³ / ₄	8 ⁵ / ₁₆	10 ⁷ / ₈	10 ⁹ / ₁₆	12 ¹ / ₈	70 lbs.
	mm	—	—	203	133	89	165	102	221	156	98	222	211	276	268	308	32 kg
TX(S)D2.5	in.	1 ¹ / ₈	1 ¹ / ₄	8 ³ / ₄	6	4 ⁷ / ₈	7	4	9 ⁵ / ₈	6 ¹³ / ₁₆	3 ¹⁵ / ₁₆	9 ¹ / ₂	8 ¹¹ / ₁₆	11 ⁵ / ₈	11 ⁵ / ₁₆	13 ⁵ / ₁₆	94 lbs.
	mm	—	—	222	152	124	178	102	244	173	100	241	221	295	287	338	43 kg
TX(S)D3	in.	1 ¹ / ₈	1 ¹ / ₄	9 ⁵ / ₈	6 ⁷ / ₁₆	4 ³ / ₈	7 ¹ / ₄	5 ³ / ₈	12 ¹³ / ₁₆	8 ⁹ / ₁₆	4 ¹⁵ / ₁₆	10 ¹¹ / ₁₆	9 ⁷ / ₁₆	12 ³ / ₈	15 ³ / ₈	152 lbs.	
	mm	—	—	244	164	111	184	137	325	217	125	271	240	314	391	69 kg	
TX4	in.	1 ¹ / ₂	3 ³ / ₈	11	8 ¹ / ₄	7	9 ¹ / ₂	6 ³ / ₈	15 ¹ / ₂	8 ¹ / ₂	6 ³ / ₈	—	—	—	—	295 lbs.	
	mm	—	—	279	210	178	241	162	394	217	162	—	—	—	—	134 kg	

Pump Rotation

Blackmer TX(S)D models are equipped with a double-ended drive shaft for either clockwise (RH) or counterclockwise (LH) rotation. Standard rotation for the TX1.5 is counterclockwise (LH) when viewed from the drive shaft. Standard rotation for the TX4 model is clockwise (RH).

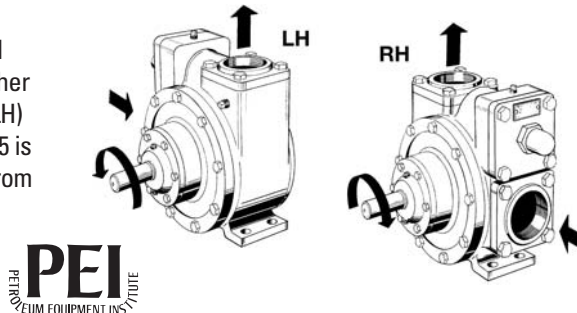

Options

- FKM or PTFE O-rings
- Mechanical seals with stainless steel stationary seats
- Laminate vanes
- Pneumatic relief valve
- Hydraulic Motor Adapters
- Strainers

Distributed by:



World Headquarters
1809 Century Avenue SW
Grand Rapids, MI 49503-1530 USA
T 616.241.1611 F 616.241.3752

European Headquarters
ZI la Plaine des Isles, rue des Caillottes,
89000 Auxerre, FRANCE
T +33.3.86.49.86.30 F +33.3.86.46.42.10

