



SX3 Series

Stainless Steel Vane Pump
for Corrosive, Thin Liquid
Process Applications at
High Capacities

- 3-inch ported pump
- Capacity to 250 gpm (56 m³/hr)
- Pressure to 125 psi (8.6 bar)
- Viscosity 30 to 20,000 ssu (1 to 4,250 cSt)
- Temperature to 240°F (115°C)



Introducing the Blackmer SX3 Series Stainless Steel Process Vane Pump Advantage

The Leading Authority in Vane Pump Design

For more than 100 years, Blackmer vane pumps have set the industry standard for the transfer of thin liquids in a broad range of process applications, including corrosive and non-corrosive chemicals, solvents, sulfates, vegetable oils, urea and many acids.

With more than a century of vane technology experience, Blackmer is the leading authority on vane technology design and construction. We know that efficiency and high performance is attained through experienced pump design with a complete understanding of the bearing environment – which is why every Blackmer vane pump design begins with field-proven designs, materials of construction and with the bearings and seals in mind – the most common failure points for other PD pumps.

Field-Proven Reliability and Performance

The Blackmer SX3 Stainless Steel Process Vane Pump is built around the design of the popular STX3, the most specified chemical transport pump in the world. With a field-proven track record for high volumetric performance and reliability as its foundation, the SX3 ensures long, trouble-free operation and high efficiency in process applications.



High-Capacity Performance

For unbeatable durability, reliability and the lowest overall cost of ownership, the Blackmer SX3 Series Stainless Steel Process Vane Pump is the ideal pump for high-capacity process applications between 100 and 250 gpm (22 and 56 m³/h). Designed for a wide range of chemical applications and compatibility, the SX3 features Duravanes® and external ball bearings protected by chemical mechanical seals with PTFE elastomers. The pump's performance offers low shear, non-pulsing flow and pressure capabilities to 125 psi (8.6 bar) with superior vacuum capabilities for self-priming, loading/unloading and line stripping applications.

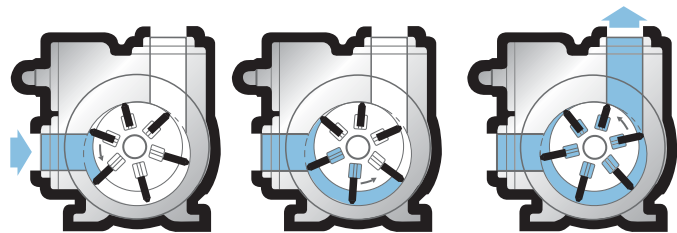

How Blackmer's sliding vane action works

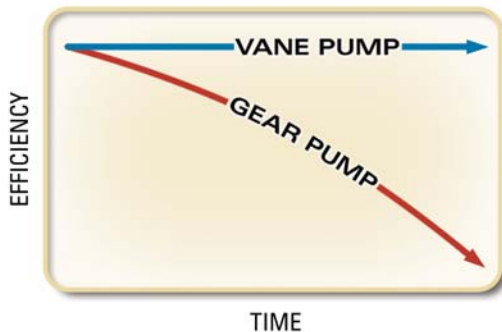

The Sliding Vane Advantage: High-Performance, Sustained Efficiency

Due to its self-adjusting nature, and the close tolerances of the sliding vanes, sliding vane technology maintains the highest level of performance and efficiency over any other pump technology to deliver unparalleled lifetime reliability and flow performance.

Construction

Constructed of 316 stainless steel, SX3 pumps are specifically engineered for low and medium viscosity process applications where reliable, continuous duty operation with no preventative maintenance is desired. SX3 pumps are ideal for handling shear-sensitive liquids at high speeds with no product degradation.

Self-Adjusting Duravanes®

- Long-lasting, nonmetallic composite vanes automatically adjust clearances and sustain the highest levels of flow performance, efficiency and reliability over other PD pump technologies
- Eliminate slip, capacity loss, and downtime for clearance adjustments due to worn metal parts common with other pump types
- Offer exceptional suction and dry priming capability
- Ideal for handling shear-sensitive liquids at higher speeds
- Can run dry for short periods
- Quick and easy to replace seals and service parts when required

Drains

- Equipped with drain plugs to allow easy draining after flushing

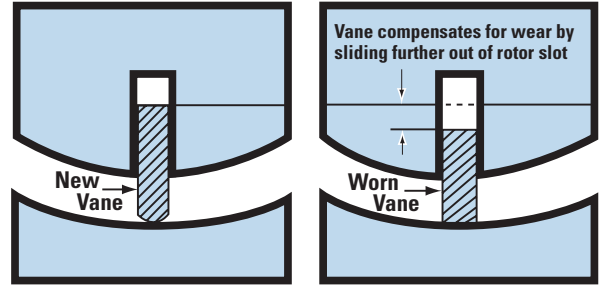

How Blackmer's sliding vanes self-adjust for wear

Blackmer Chemical Mechanical Seal

- Specially developed for thin liquids and non-lubricating liquids, Blackmer's exclusive component type design is field-proven to provide long life for a wide range of applications

Heavy-Duty Shaft

- Capable of clockwise or counterclockwise rotation

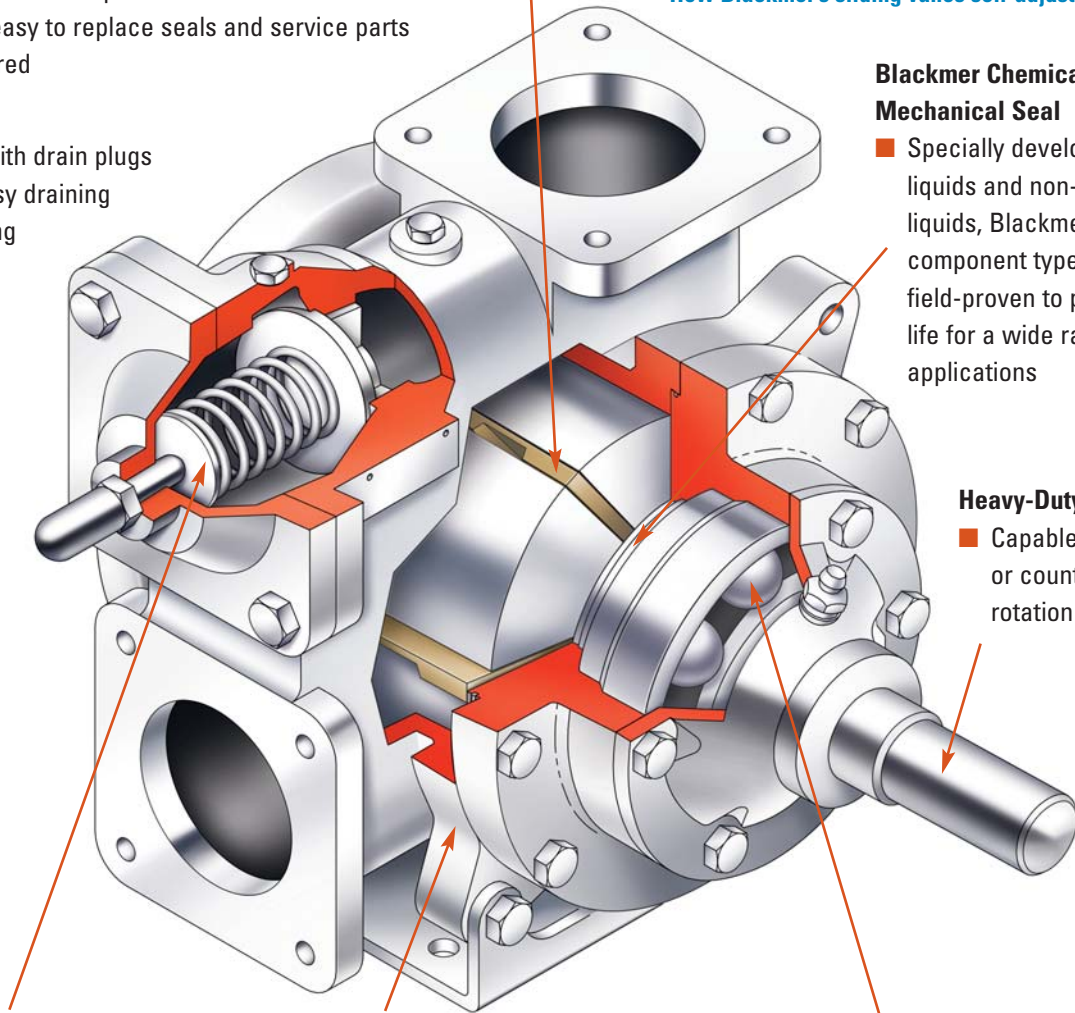

Adjustable Bypass Relief Valve

- Protects the pump from excessive pressure buildup in the event of an obstructed or closed return line

Pump Housing

- 316 stainless steel
- Field-proven design based on the STX3, the most specified chemical transport pump in the world

External Ball Bearings

- Low-friction, grease-lubricated ball bearings are isolated from the pumpage by mechanical seals for trouble-free service and long life.



blackOPS: Blackmer Optimum Pump Solutions – blackOPS is a selection software program created specifically for Blackmer's positive displacement pumps and System One® centrifugal pumps. The program allows you to print (or save) your pump selection data and pump curves in a PDF format. For additional information on blackOPS, log onto www.blackmer.com.



SX3 Series Stainless Steel Sliding Vane Pumps for Process Applications

Characteristic Flow Rates

Pump Speed	Pump Capacity @ 50 psid (3.45 bar) with 100 ssu (22 cSt) Fluid			Maximum Fluid Viscosity at rpm Shown	
	US gpm	lpm	m ³ /h	ssu	cSt
800	250	946	56	500	105
700	220	832	50	500	105
600	190	719	43	5,000	1,050
500	150	576	34	10,000	2,200
400	125	473	28	20,000	4,250

Application Assistance

In some applications, selecting the right pump may require more detailed information than can be presented in this Spec Sheet. Blackmer has a worldwide distribution network to assist in specifying the proper pump for your application.

Please contact Blackmer's Application Engineering Group at the telephone or fax number listed below for the name of your nearest Blackmer distributor.

Pump Rotation

Standard rotation for Blackmer's SX3 pump models is clockwise (RH) when viewed from the driven shaft. Counterclockwise (LH) rotation is available – please specify if required or see the SX3 IOM manual.

Pump Horsepower Requirements

Pump Speed	50 ssu (13 cSt) Viscosity		500 ssu (105 cSt) Viscosity		5,000 ssu (1,050 cSt) Viscosity		10,000 ssu (2,200 cSt) Viscosity		20,000 ssu (4,250 cSt) Viscosity		
	rpm	50 psi (3.45 bar)	100 psi (6.9 bar)	50 psi (3.45 bar)	100 psi (6.9 bar)	50 psi (3.45 bar)	100 psi (6.9 bar)	50 psi (3.45 bar)	100 psi (6.9 bar)	50 psi (3.45 bar)	100 psi (6.9 bar)
800	9.8	17.9	11.0	19.0	–	–	–	–	–	–	–
700	8.2	15.3	9.2	16.1	–	–	–	–	–	–	–
600	6.9	13.2	7.6	13.5	10.0	16.3	–	–	–	–	–
500	5.5	10.6	6.1	11.0	8.0	13.2	9.1	14.3	–	–	–
400	4.3	8.3	4.7	8.5	6.1	10.3	6.9	11.1	8.3	12.4	–

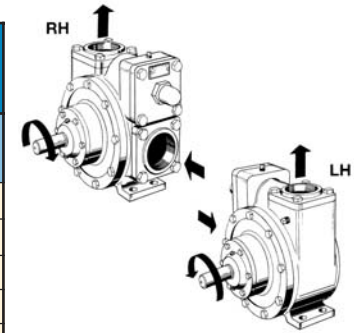

Refer to Blackmer Characteristic Curves for flow rates and torque requirements for your specific conditions.

Maximum Operating Limits

Nominal Flow Rate			Pump Speed	Viscosity		Differential Pressure		Temperature ¹	
US gpm	lpm	m ³ /h		ssu	cSt	psi	bar	°F	°C
250	946	56	800	20,000	4,250	125	8.6	240	115

¹For higher temperature or viscosity conditions, consult factory.

Pump Dimensions

Pump Model	A	B	C	D	E	F	G	H	J	K	L	M	N	P	Q	R	S	T	U	V	W	X	Y	Z	Approx. Weight	
SX3A	in.	1.375	0.393	2.14	9.53	7.00	5.00	7.28	0.53	6.25	8.04	0.25	5.38	3.12	10.62	11.56	–	8.00	4.63	5.25	2.25	–	1.25	1.25	0.313	132 lbs.
	mm	35	10	54.4	241.9	177.8	127	184.9	13.5	158.8	204.2	6.4	136.7	79.3	269.7	293.7	–	203.2	117.6	133.4	57.2	–	31.8	31.8	7.9	60 kg

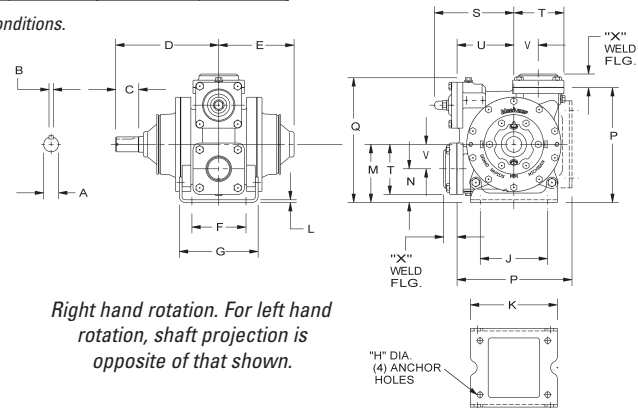

Right hand rotation. For left hand rotation, shaft projection is opposite of that shown.



Distributed by:

World Headquarters
1809 Century Avenue SW
Grand Rapids, MI 49503-1530 USA
T 616.241.1611 F 616.241.3752

European Headquarters
ZI Plaine des Isles, 2 rue des Caillottes,
89000 Auxerre, FRANCE
T +33.3.86.49.86.30 F +33.3.86.46.42.10



www.blackmer.com